

Features

- Uses PingWei advanced PerfectMOS2 technology
- Extremely low on-resistance $R_{DS(on)}$
- Excellent $Q_g \times R_{DS(on)}$ product(FOM)
- Qualified according to AEC-Q101 criteria

Benefits

- High robustness and reliability
- Increases maximum current capability
- Low power loss, high power density

Applications

- General automotive applications
- Motor Drivers
- DC-DC



100% DVDS Tested
100% Avalanche Tested

Product Summary

V_{DS}	40V
$R_{DS(on)}@10V$ typ	8.3mΩ
I_D (Silicon)	45A

DFN5x6双基岛

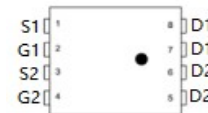
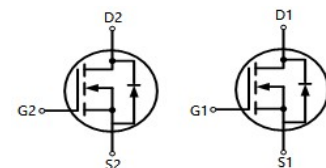
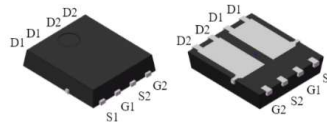

Package Marking and Ordering Information

Part #	Marking	Package	Packing	Reel Size	Tape Width	Qty
PWC100N04ESDQ	C100N04ESDQ	DFN5x6双基岛	Tape&Reel	13 inches	12mm	5000pcs

Absolute Maximum Ratings

Parameter	Symbol	Value	Unit
Drain-source voltage	V_{DS}	40	V
Continuous drain current	I_D	45	A
$T_C = 25^\circ\text{C}$ (Silicon limit)		40	
$T_C = 25^\circ\text{C}$ (Package limit)		31	
$T_C = 100^\circ\text{C}$ (Silicon limit)		12	
$T_a = 25^\circ\text{C}$ (See RthJA)			
Pulsed drain current ($T_C = 25^\circ\text{C}, t_p=100\mu\text{s}$)	$I_{D \text{ pulse}}$	124	A
Avalanche energy, single pulse ($L=0.1\text{mH}$)	E_{AS}	25	mJ
Gate-Source voltage	V_{GS}	± 20	V
Power dissipation	P_{tot}	38	W
$T_C = 25^\circ\text{C}$			
Operating junction and storage temperature	T_j, T_{stg}	-55...+175	$^\circ\text{C}$
Reflow soldering temperature (10s)	T_{sold}	260	$^\circ\text{C}$

Thermal Resistance

Parameter	Symbol	Value			Unit	Test Condition
		min.	typ.	max.		
Thermal resistance, junction - case.	RthJC	-	-	4.0	°C/W	-
Thermal resistance, junction - ambient	RthJA	-	53	-	°C/W	15mm x 15mm x 1.6mm, 1oz single Copper FR-4.

Electrical Characteristic (at Tj = 25 °C, unless otherwise specified)

Parameter	Symbol	Value			Unit	Test Condition
		min.	typ.	max.		

Static Characteristic

Drain-source breakdown voltage	BV _{DSS}	40	-	-	V	V _{GS} =0V, I _D =250uA
Gate threshold voltage	V _{GS(th)}	2.0	-	4.0	V	V _{DS} =V _{GS} , I _D =250uA
Zero gate voltage drain current	I _{DSS}	-	0.01	1	μA	V _{DS} =40V, V _{GS} =0V T _j =25°C T _j =125°C
Gate-source leakage current	I _{GSS}	-	±10	±100	nA	V _{GS} =±20V, V _{DS} =0V
Drain-source on-state resistance	R _{DS(on)}	-	8.3	10.5	mΩ	V _{GS} =10V, I _D =20A
Transconductance	g _{fs}	-	18	-	S	V _{DS} =5V, I _D =20A

Dynamic Characteristic

Input Capacitance	C _{iss}	-	585	-	pF	V _{GS} =0V, V _{DS} =20V, f=100KHz
Output Capacitance	C _{oss}	-	217	-		
Reverse Transfer Capacitance	C _{rss}	-	9	-		
Gate Total Charge	Q _G	-	9	-	nC	V _{DS} =20V, I _D =20A, V _{GS} =10V
Gate-Source charge	Q _{gs}	-	4	-		
Gate-Drain charge	Q _{gd}	-	1	-		
Turn-on delay time	t _{d(on)}	-	5	-	ns	V _{GS} =10V, V _{DD} =20V, I _D =20A, R _G =1.6Ω
Rise time	t _r	-	6	-		
Turn-off delay time	t _{d(off)}	-	10	-		
Fall time	t _f	-	2	-		
Gate resistance	R _G	-	2.2	-	Ω	V _{GS} =0V, V _{DS} =0V, f=1MHz

Body Diode Characteristic

Parameter	Symbol	Value			Unit	Test Condition
		min.	typ.	max.		
Body Diode Forward Voltage	V_{SD}	-	-	1.2	V	$V_{GS}=0V, I_{SD}=20A$
Body Diode Continuous Forward Current	I_S	-	-	40	A	TC = 25°C
Body Diode Pulsed Current	I_S pulse	-	-	124	A	TC = 25°C, $t_p = 100\mu s$
Body Diode Reverse Recovery Time	t_{rr}	-	7	-	ns	$V_D=20V, I_F=20A,$ $dI/dt=100A/\mu s$
Body Diode Reverse Recovery Charge	Q_{rr}	-	1	-	nC	

Typical Performance Characteristics

Fig 1: Output Characteristics

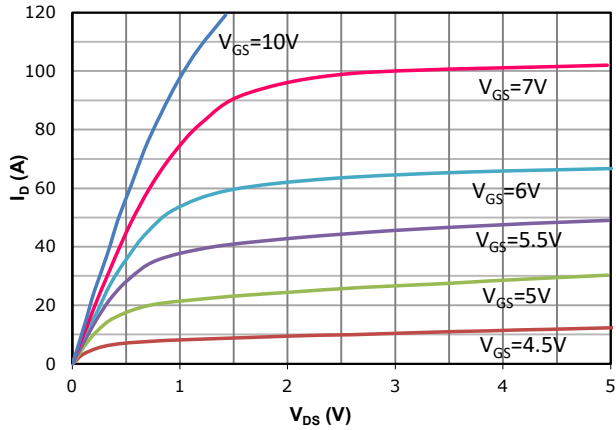

Fig 2: Transfer Characteristics

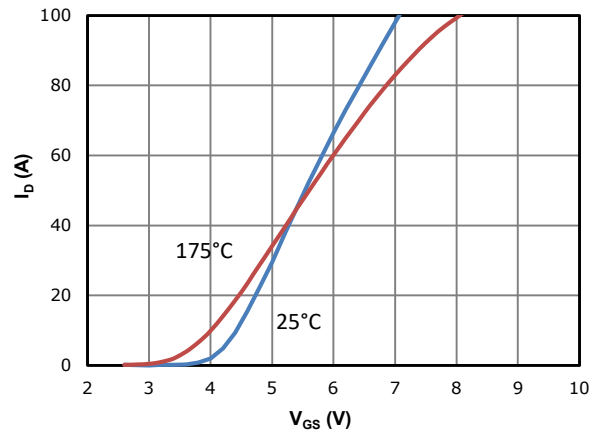

Fig 3: $R_{DS(on)}$ vs Drain Current and Gate Voltage

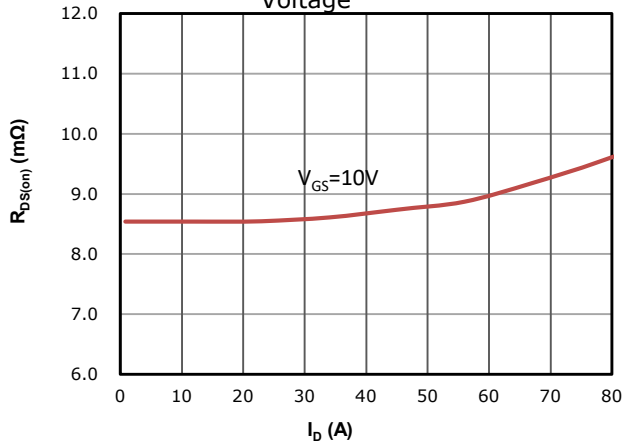

Fig 4: $R_{DS(on)}$ vs Gate Voltage

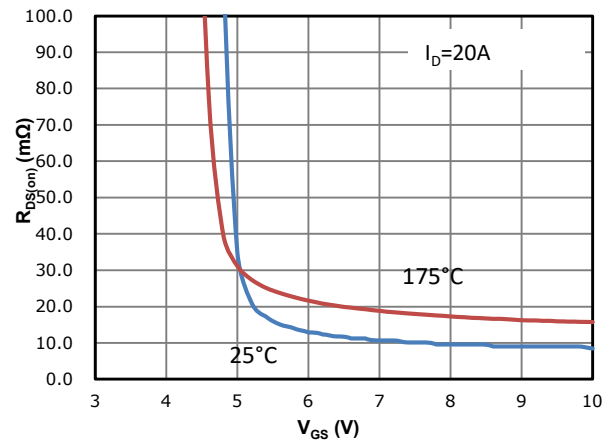

Fig 5: $R_{DS(on)}$ vs. Temperature

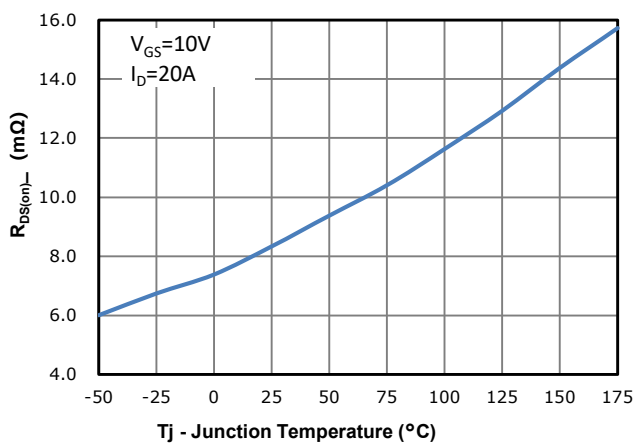

Fig 6: $V_{GS(th)}$ vs. Temperature

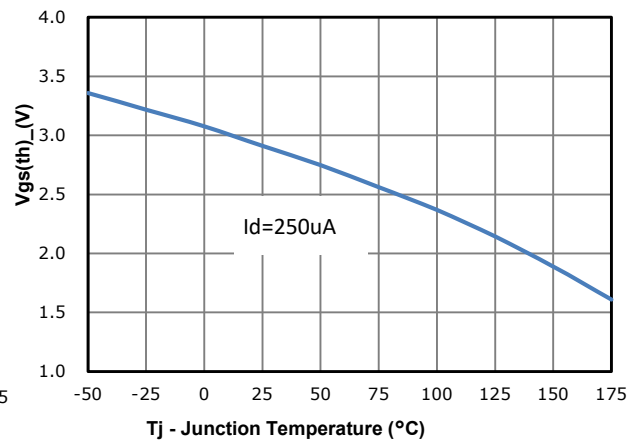

Fig 7: BVdss vs. Temperature

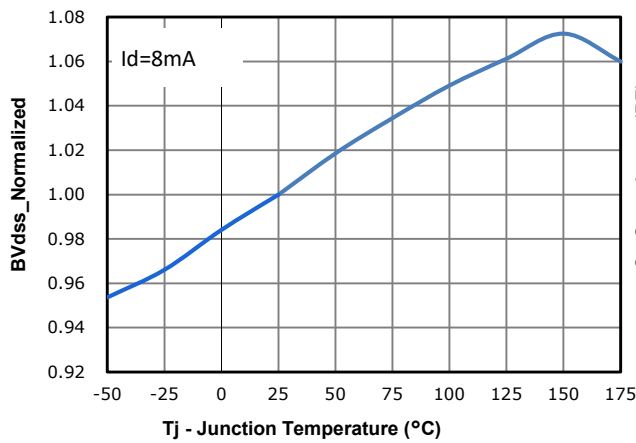

Fig 8: Capacitance Characteristics

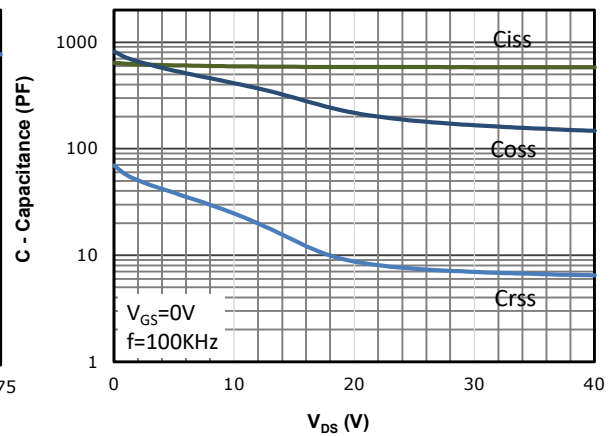

Fig 9: Gate Charge Characteristics

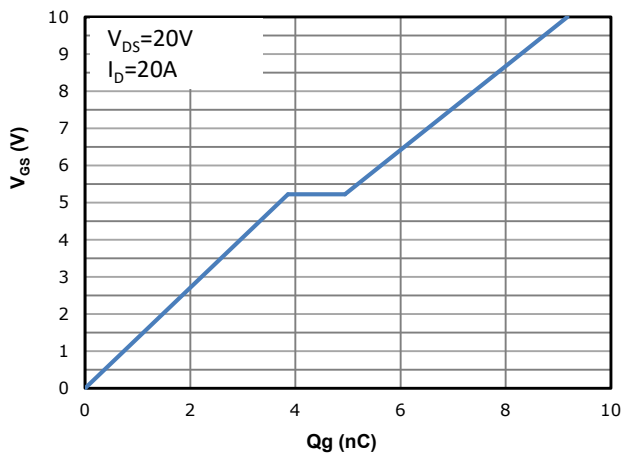

Fig 10: Body-diode Forward Characteristics

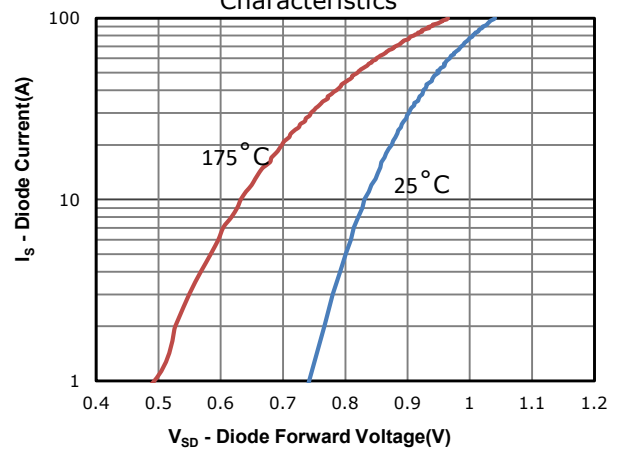

Fig 11: Power Dissipation

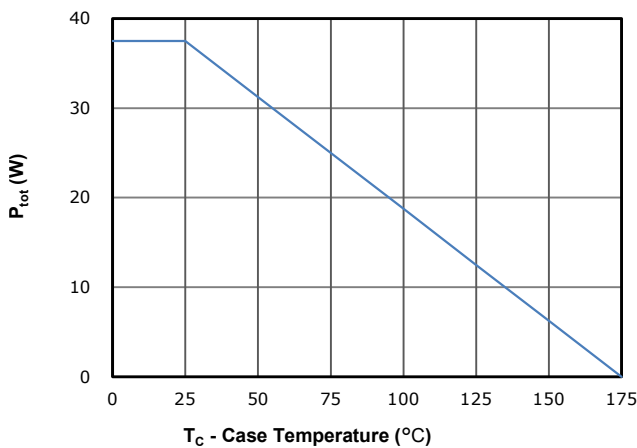

Fig 12: Drain Current Derating

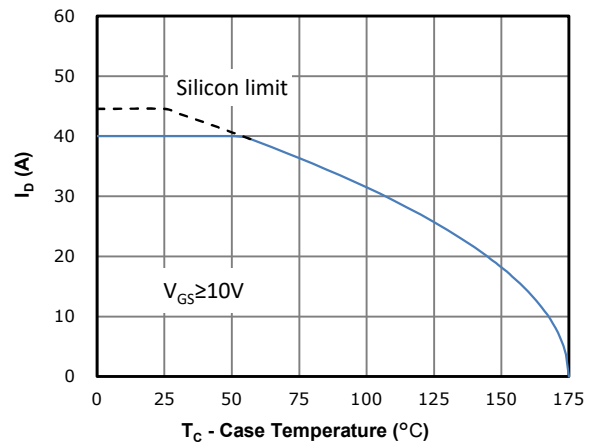

Fig 13: Safe Operating Area

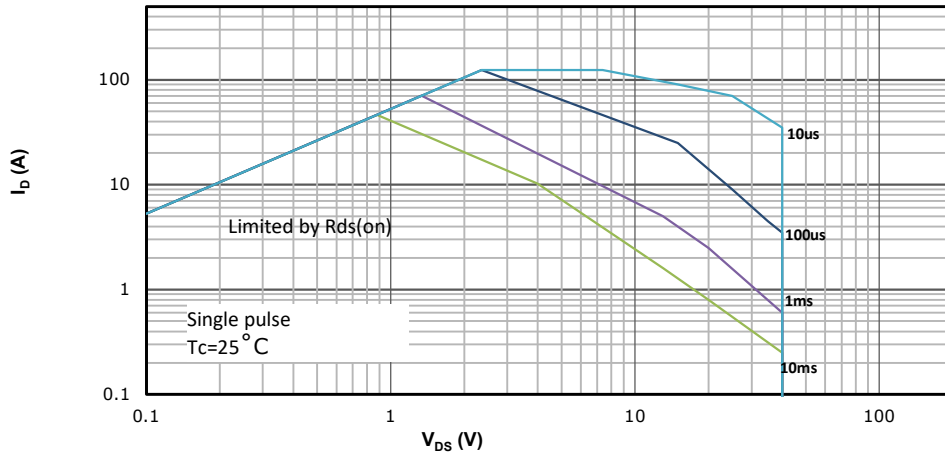
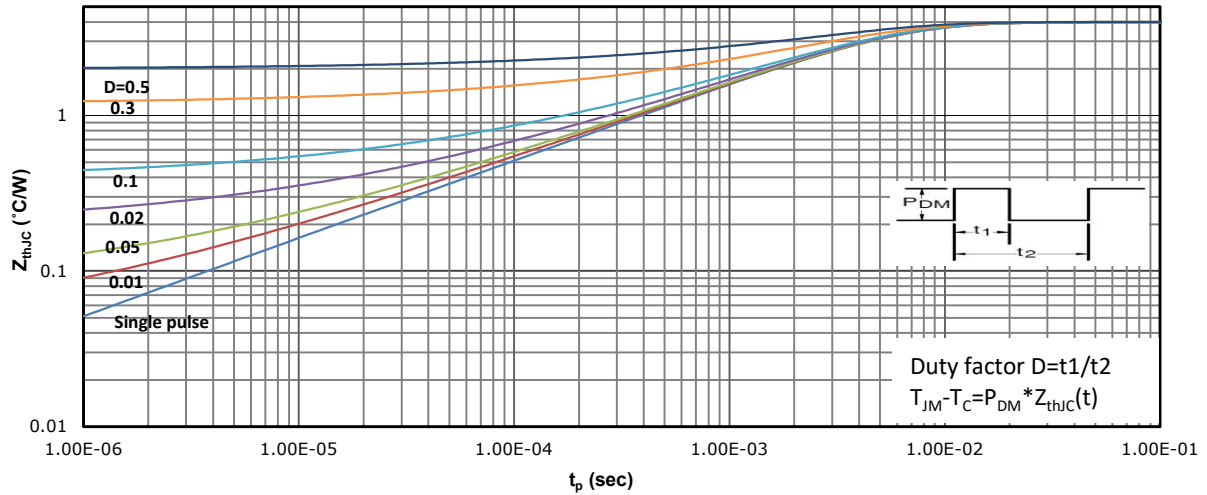
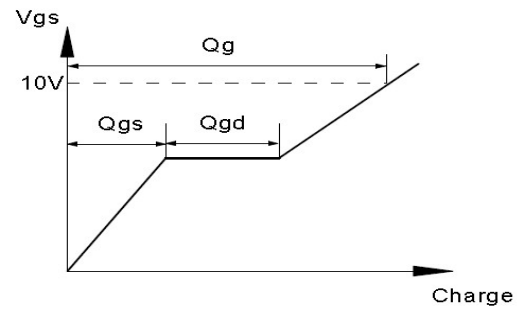
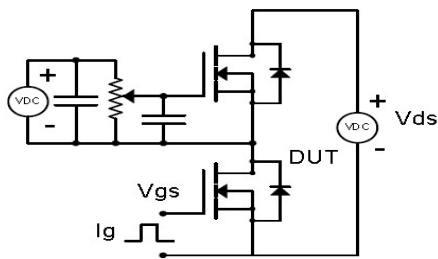

Fig 14: Max. Transient Thermal Impedance



Test Circuit & Waveform

Gate Charge Test Circuit & Waveform



Resistive Switching Test Circuit & Waveforms

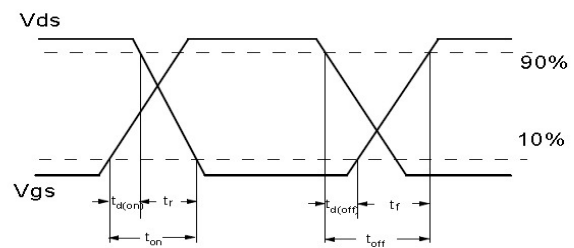
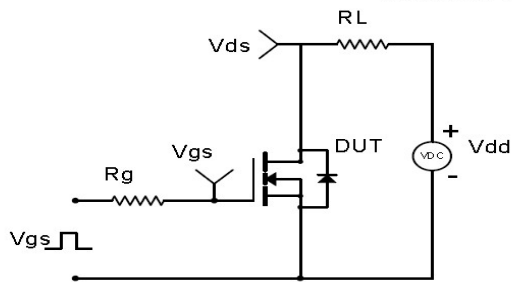

Unclamped Inductive Switching (UIS) Test Circuit & Waveforms

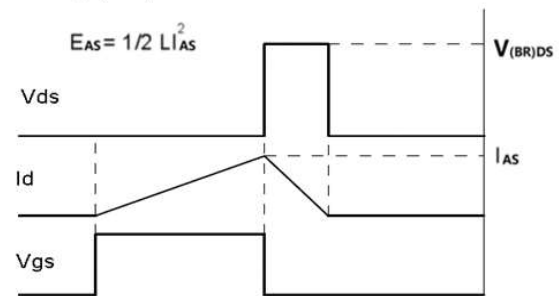
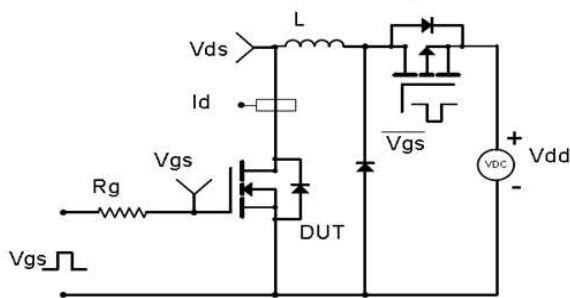

Diode Recovery Test Circuit & Waveforms

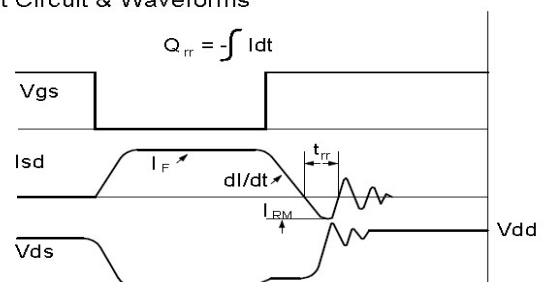
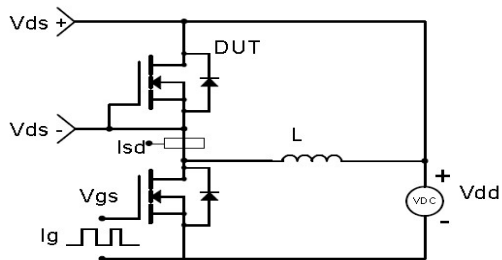

Package Outline: DFN5×6 Double Base Island Package Outline

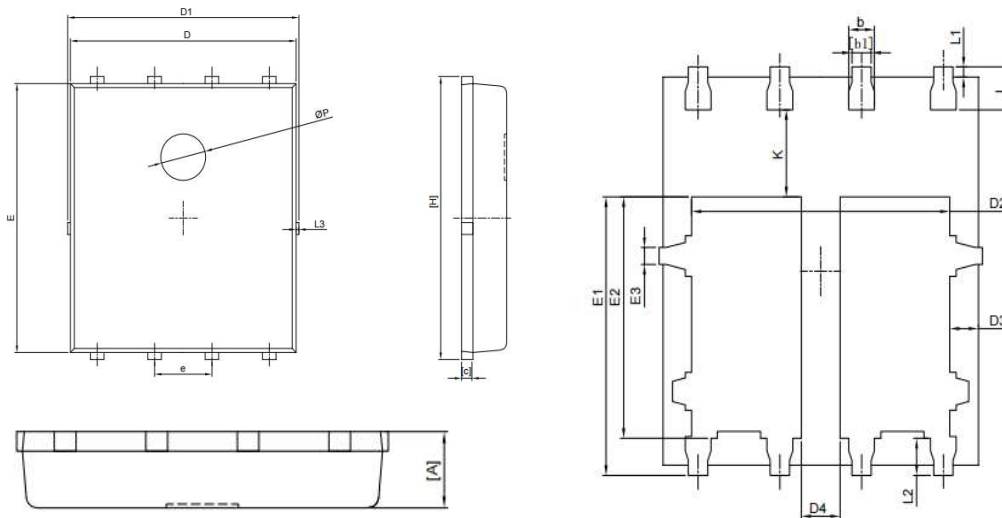

SYMBOL	MILLIMETERS		INCHES	
	MIN	MAX	MIN	MAX
A	0.90	1.10	0.035	0.043
b	0.30	0.50	0.012	0.020
b1	0.20	0.40	0.008	0.016
c	0.20	0.30	0.008	0.012
D	4.80	5.20	0.189	0.205
D1	5.00	5.30	0.197	0.209
D2	3.81	4.21	0.150	0.166
D3	0.24	0.64	0.009	0.025
D4	0.45	0.75	0.018	0.030
E	5.55	5.95	0.219	0.234
E1	3.88	4.38	0.153	0.172
E2	3.32	3.82	0.131	0.150
E3	0.15	0.45	0.006	0.018
e	1.27		0.050	
H	5.95	6.15	0.234	0.242
L	0.44	0.84	0.017	0.033
L1	0.05	0.25	0.002	0.010
L2	0.35	0.75	0.014	0.030
L3	-	0.22	-	0.009
K	1.09	1.49	0.043	0.059
P	0.80	1.20	0.031	0.047



Revision History

Revision	Date	Major changes
1.0	2026/6/16	Release of Formal Version.

Disclaimer

Any and all semiconductor products have certain probability to fail or malfunction, which may result in personal injury, death or property damage. Customer are solely responsible for providing adequate safe measures when design their systems.

The product is not intended for use in applications that require extraordinary levels of quality and reliability, such as aviation/aerospace and life-support devices or systems.

Buyer is responsible for its products and applications using PingWei products, including compliance with all laws, regulations and safety requirements or standards, regardless of any support or applications information provided by PingWei.

"Typical" parameters which may be provided in PingWei data sheets and/or specifications can and do vary in different applications and actual performance may vary over time. All operating parameters, including "Typicals" must be validated for each customer application by customer's technical experts

ALL PRODUCT, PRODUCT SPECIFICATIONS AND DATA ARE SUBJECT TO CHANGE WITHOUT NOTICE TO IMPROVE RELIABILITY, FUNCTION OR DESIGN OR OTHERWISE