

D8KB6A THRU D8KB10A

SINGLE PHASE 8.0AMPS.GLASS PASSIVATED BRIDGE RECTIFIERS

FEATURE

- . UL Listed Under Recognized Component Index, File Number E338195
- . Glass passivated chip junctions
- . High case dielectric strength
- . Low Reverse Leakage Current
- . High surge current capability
- . Ideal for Printed Circuit Board Applications

MECHANICAL DATA

- . Case Material: Molded Plastic.
UL Flammability Classification Rating 94V-0
- . Terminals: Pure tin plated, Lead free.
Leads solderable per MIL-STD-750, Method 2026.
- . Polarity: Marked on body
- . Mounting position: Any

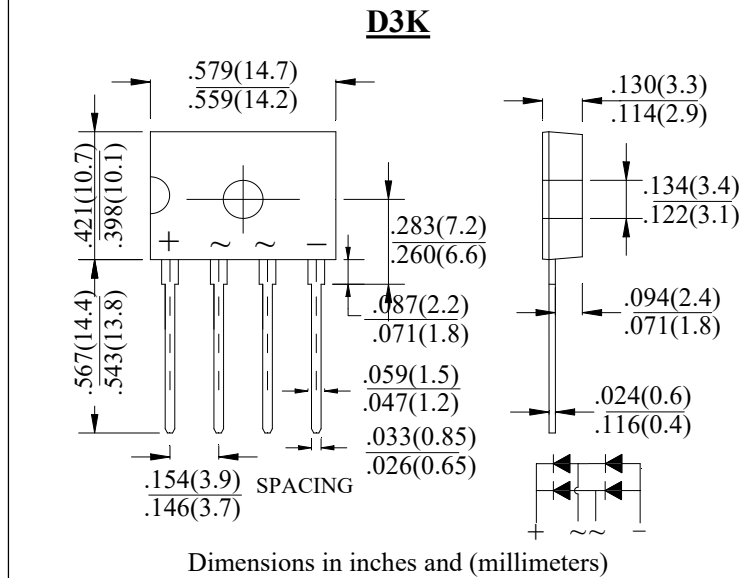

MAXIMUM RATINGS AND ELECTRICAL CHARACTERISTICS

Ratings at 25°C ambient temperature unless otherwise specified.

Single phase, half wave, 60Hz, resistive or inductive load. For capacitive load, derate current by 20%

| Type Number | SYM BOL | D8KB6A | D8KB8A | D8KB10A | units |
|---|-------------|--------|--------------|---------|------------------------|
| Maximum Recurrent Peak Reverse Voltage | V_{RRM} | 600 | 800 | 1000 | V |
| Maximum RMS Voltage | V_{RMS} | 420 | 560 | 700 | V |
| Maximum DC blocking Voltage | V_{DC} | 600 | 800 | 1000 | V |
| Maximum Average Forward (with heatsink Note2) Rectified Current @ $T_C=100^\circ\text{C}$ (without heatsink) | $I_{F(AV)}$ | | 8.0 3.0 | | A |
| Peak Forward Surge Current @ $T_J=25^\circ\text{C}$ 8.3ms single half sine-wave @ $T_J=125^\circ\text{C}$ | I_{FSM} | | 170 140 | | A |
| Peak Forward Surge Current @ $T_J=25^\circ\text{C}$ 1.0ms single half sine-wave @ $T_J=125^\circ\text{C}$ | I_{FSM} | | 330 280 | | A |
| Maximum Forward Voltage @ 8.0A DC Drop per element @ 4.0 A DC | V_F | | 1.1 1.0 | | V |
| Maximum DC Reverse Current @ $T_J=25^\circ\text{C}$ at rated DC blocking voltage @ $T_J=125^\circ\text{C}$ | I_R | | 5.0 500.0 | | μA |
| I^2t Rating for Fusing ($t < 8.3\text{ms}$) | I^2t | | 119 | | A^2Sec |
| Typical Junction Capacitance (Note 1) | C_J | | 50 | | pF |
| Typical Thermal Resistance (Note 2) | $R_{(JA)}$ | | 25 | | $^\circ\text{C/W}$ |
| | $R_{(JC)}$ | | 2.8 | | |
| Storage Temperature | T_{STG} | | -55 to +150 | | $^\circ\text{C}$ |
| Operating Junction Temperature | T_J | | -55 to +150 | | $^\circ\text{C}$ |

Note:

1. Measured at 1.0 MHz and applied reverse voltage of 4.0Vdc
2. Device mounted on 100mm x 100mm x 1.6mm Cu Plate Heatsink.

RATING AND CHARACTERISTIC CURVES

FIG.1-TYPICAL FORWARD CURRENT DERATING CURVE

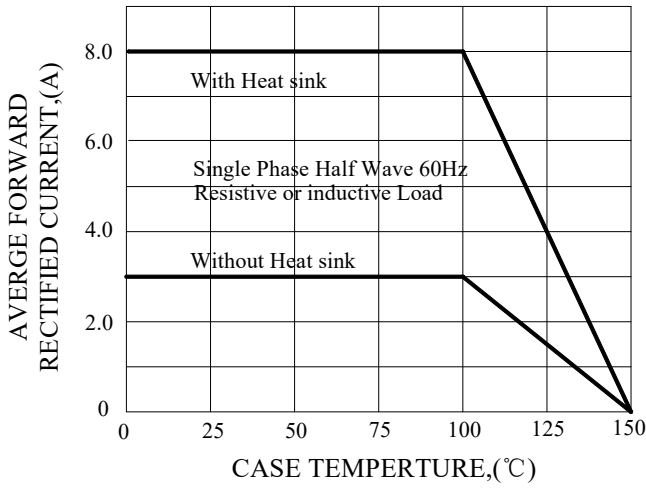

FIG.2-TYPICAL INSTANTANEOUS FORWARD CHARACTERISTICS

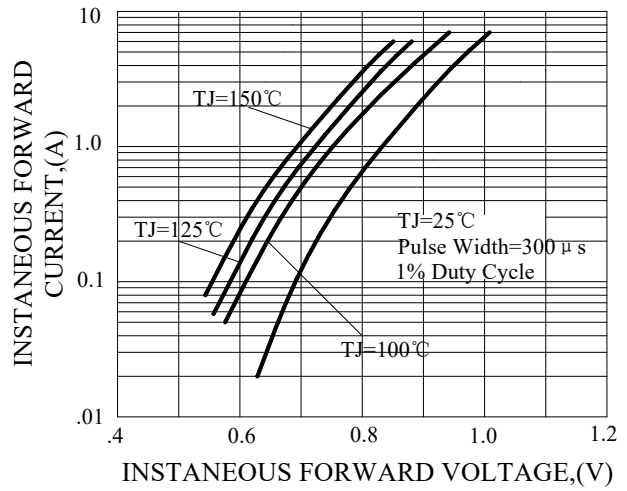

FIG.3-MAXIMUM NON-REPETITIVE FORWARD SURGE CURRENT

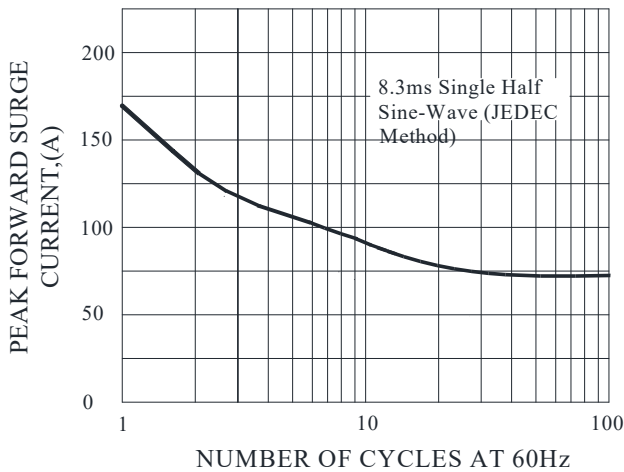

FIG.4-TYPICAL JUNCTION CAPACITANCE

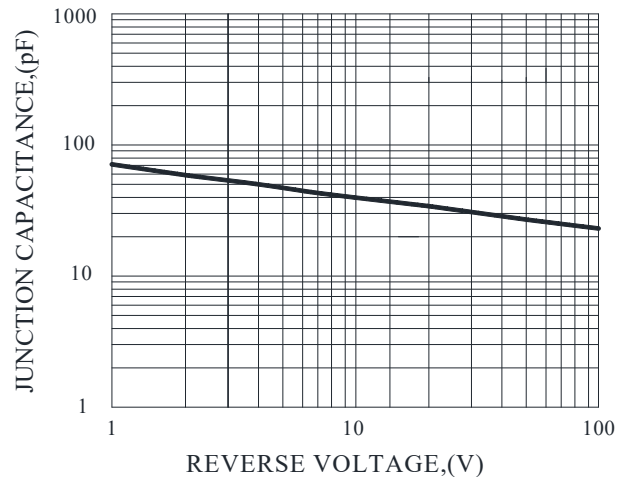
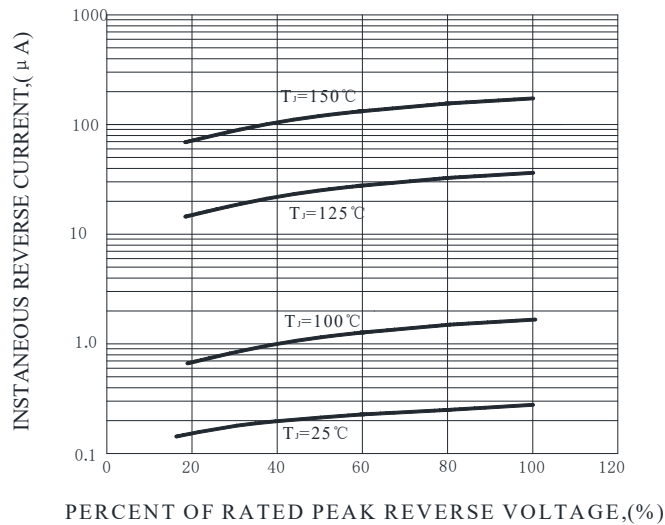
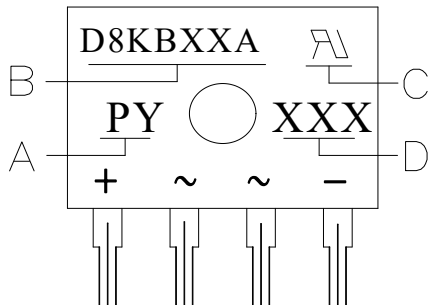

FIG.5-TYPICAL REVERSE CHARACTERISTICS



Marking and packaging illustration

1、Marking



| SYMBOL | Explanation |
|--------|--------------|
| A | Trademark |
| B | Product Name |
| C | UL |
| D | Data Code |

2、Packaging

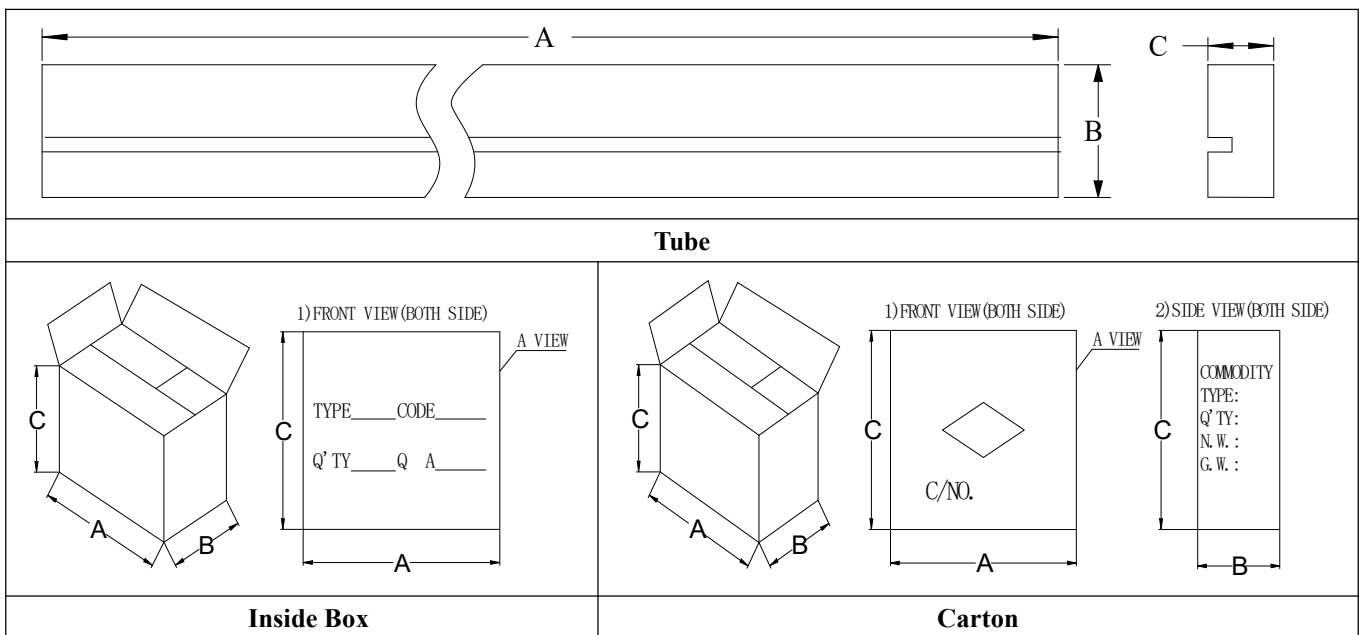

| OUTLINE | A (mm) | B (mm) | C (mm) |
|-----------|-----------|-----------|-----------|
| Tube | 390±1 | 28.8±1 | 6.1±1 |
| Inner box | 395±3 | 155±3 | 155±3 |
| Carton | 420±5 | 180±5 | 325±5 |

| COUNT | TUBE (PCS) | BOX (PCS) | CARTON (PCS) |
|-------|---------------|--------------|-----------------|
| D3K | 25 | 2500 | 5000 |