

## Features

- Uses PingWei advanced PerfectMOS2 technology
- Extremely low on-resistance  $R_{DS(on)}$
- Excellent  $Q_g \times R_{DS(on)}$  product(FOM)
- Qualified according to AEC-Q101 criteria

## Benefits

- High robustness and reliability
- Increases maximum current capability
- Low power loss, high power density

## Applications

- General automotive applications
- Power bus switch
- DC-DC Power



**100% DVDS Tested**  
**100% Avalanche Tested**

## Product Summary

$V_{DS}$	-40V
$R_{DS(on)}@10V$ typ	3.5mΩ
$I_D$ (Silicon)	-133A

DFN5\*6

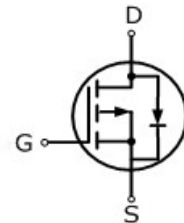
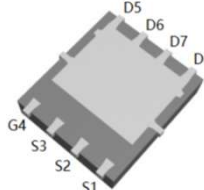
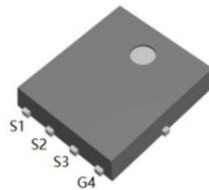

## Package Marking and Ordering Information

Part #	Marking	Package	Packing	Reel Size	Tape Width	Qty
PWC040P04ESQ	C040P04ESQ	DFN5*6	Tape&Reel	13 inches	12mm	5000pcs

## Absolute Maximum Ratings

Parameter	Symbol	Value	Unit
Drain-source voltage	$V_{DS}$	-40	V
Continuous drain current	$I_D$	-133	A
$T_C = 25^\circ\text{C}$ (Silicon limit)		-120	
$T_C = 25^\circ\text{C}$ (Package limit)		-94	
$T_C = 100^\circ\text{C}$ (Silicon limit)		-23	
$T_a = 25^\circ\text{C}$ (See RthJA)	$I_{D \text{ pulse}}$	-480	A
Pulsed drain current ( $T_C = 25^\circ\text{C}$ )	$E_{AS}$	133	mJ
Avalanche energy, single pulse (L=0.1mH)	$V_{GS}$	$\pm 20$	V
Gate-Source voltage	$P_{tot}$	125	W
Power dissipation		3.9	
$T_C = 25^\circ\text{C}$ $T_a = 25^\circ\text{C}$ (See RthJA)			
Operating junction and storage temperature	$T_j, T_{stg}$	-55...+175	$^\circ\text{C}$
Soldering temperature, wave soldering only allowed at leads (1.6mm from case for 10s)	$T_{sold}$	260	$^\circ\text{C}$

## Thermal Resistance

Parameter	Symbol	Value			Unit	Test Condition
		min.	typ.	max.		
Thermal resistance, junction - case.	RthJC	-	-	1.2	°C/W	-
Thermal resistance, junction - ambient	RthJA	-	38.7	-	°C/W	1 inch <sup>2</sup> , 2oz single copper FR-4 PCB

## Electrical Characteristic (at T<sub>j</sub> = 25 °C, unless otherwise specified)

Parameter	Symbol	Value			Unit	Test Condition
		min.	typ.	max.		

### Static Characteristic

Drain-source breakdown voltage	BV <sub>DSS</sub>	-40	-	-	V	V <sub>GS</sub> =0V, I <sub>D</sub> =-250uA
Gate threshold voltage	V <sub>GS(th)</sub>	-2	-	-4	V	V <sub>DS</sub> =V <sub>GS</sub> , I <sub>D</sub> =-250uA
Zero gate voltage drain current	I <sub>DSS</sub>	-	-	-1	μA	V <sub>DS</sub> =-40V, V <sub>GS</sub> =0V T <sub>j</sub> =25°C T <sub>j</sub> =150°C
Gate-source leakage current	I <sub>GSS</sub>	-	-	±100	nA	V <sub>GS</sub> =±20V, V <sub>DS</sub> =0V
Drain-source on-state resistance	R <sub>DS(on)</sub>	-	3.5	4.1	mΩ	V <sub>GS</sub> =-10V, I <sub>D</sub> =-30A
		-	4.5	5.8		V <sub>GS</sub> =-7V, I <sub>D</sub> =-30A
Transconductance	g <sub>fs</sub>	-	60	-	S	V <sub>DS</sub> =-5V, I <sub>D</sub> =-30A

### Dynamic Characteristic

Input Capacitance	C <sub>iss</sub>	-	4560	-	pF	V <sub>GS</sub> =0V, V <sub>DS</sub> =-20V, f=1MHz
Output Capacitance	C <sub>oss</sub>	-	1270	-		
Reverse Transfer Capacitance	C <sub>rss</sub>	-	52	-		
Gate Total Charge	Q <sub>G</sub>	-	65	-	nC	V <sub>DS</sub> =-20V, I <sub>D</sub> =-30A, V <sub>GS</sub> =-10V
Gate-Source charge	Q <sub>gs</sub>	-	22	-		
Gate-Drain charge	Q <sub>gd</sub>	-	10	-		
Turn-on delay time	t <sub>d(on)</sub>	-	13	-	ns	V <sub>GS</sub> =-10V, V <sub>DD</sub> =-20V, R <sub>G_ext</sub> =1.6Ω, I <sub>D</sub> =-30A
Rise time	t <sub>r</sub>	-	79	-		
Turn-off delay time	t <sub>d(off)</sub>	-	99	-		
Fall time	t <sub>f</sub>	-	51	-		
Gate resistance	R <sub>G</sub>	-	12.5	-	Ω	V <sub>GS</sub> =0V, V <sub>DS</sub> =0V, f=1MHz

## Body Diode Characteristic

Parameter	Symbol	Value			Unit	Test Condition
		min.	typ.	max.		
Body Diode Forward Voltage	$V_{SD}$	-	-	-1.2	V	$V_{GS}=0V, I_{SD}=-30A$
Body Diode Continuous Forward Current	$I_S$	-	-	-120	A	TC = 25°C
Body Diode Pulsed Current	$I_S$ pulse	-	-	-480	A	TC = 25°C
Body Diode Reverse Recovery Time	$t_{rr}$	-	36	-	ns	$I_F=-50A,$ $dI/dt=100A/\mu s$
Body Diode Reverse Recovery Charge	$Q_{rr}$	-	26	-	nC	

Typical Performance Characteristics

Fig 1: Output Characteristics

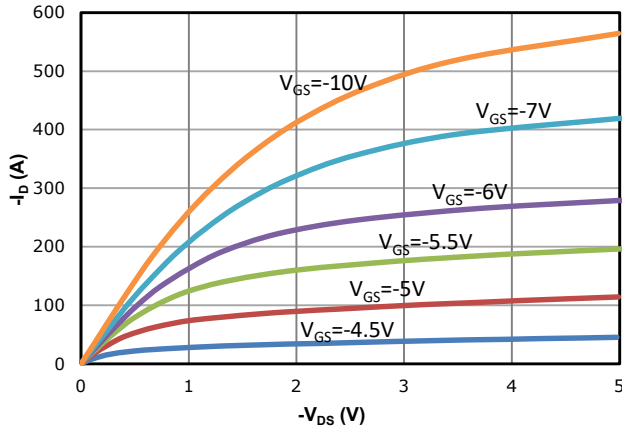

Fig 2: Transfer Characteristics

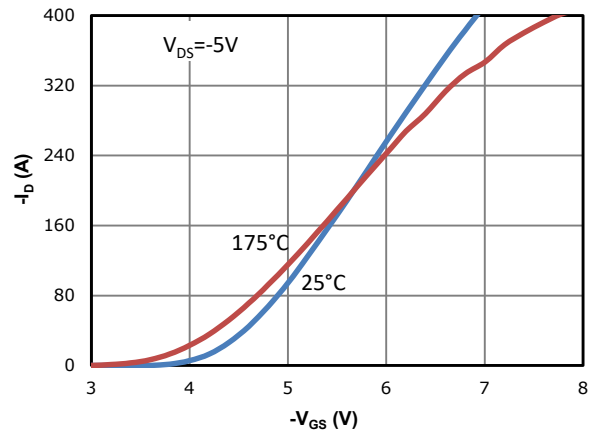

Fig 3:  $R_{DS(on)}$  vs Drain Current and Gate Voltage

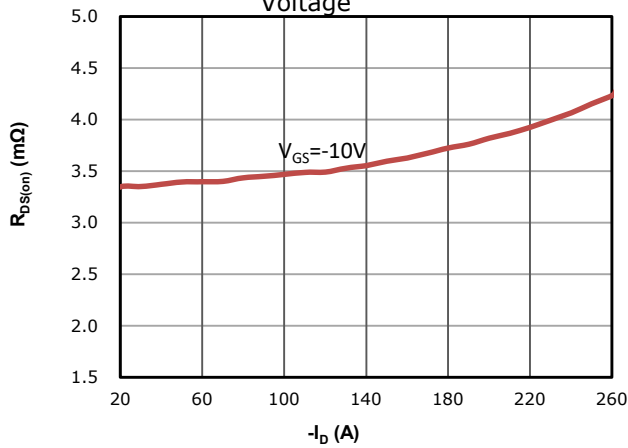

Fig 4:  $R_{DS(on)}$  vs Gate Voltage

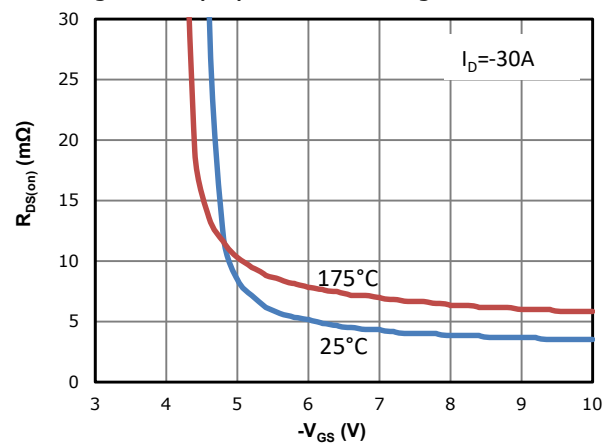

Fig 5:  $R_{DS(on)}$  vs. Temperature

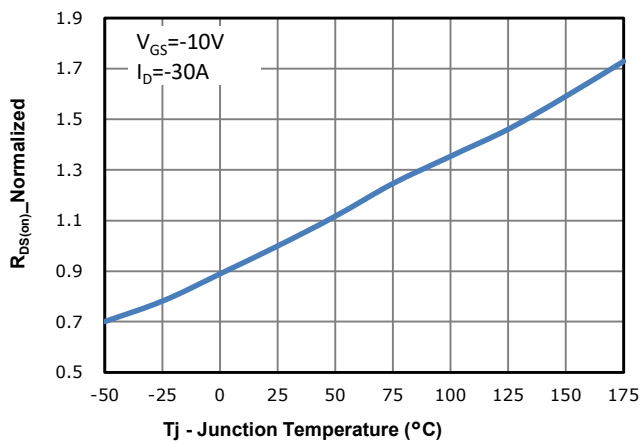

Fig 6:  $V_{GS(th)}$  vs. Temperature

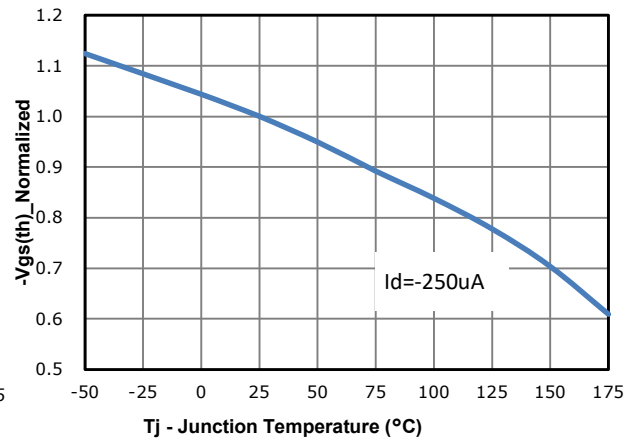

Fig 7: BVdss vs. Temperature

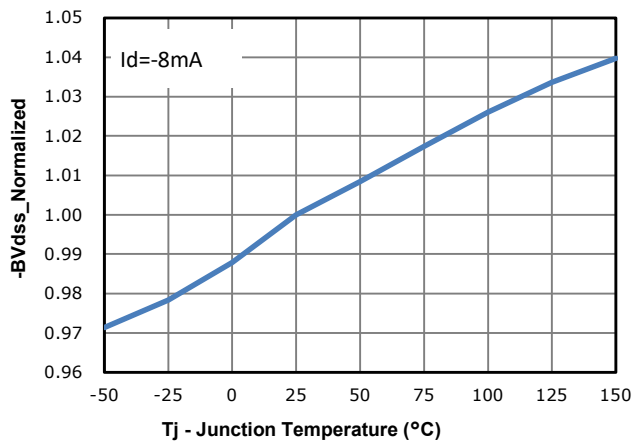

Fig 8: Capacitance Characteristics

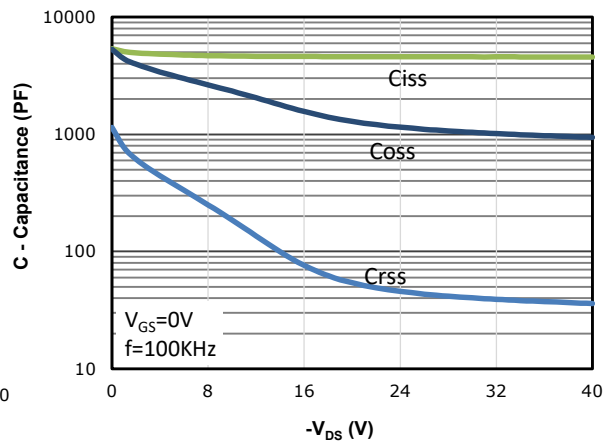

Fig 9: Gate Charge Characteristics

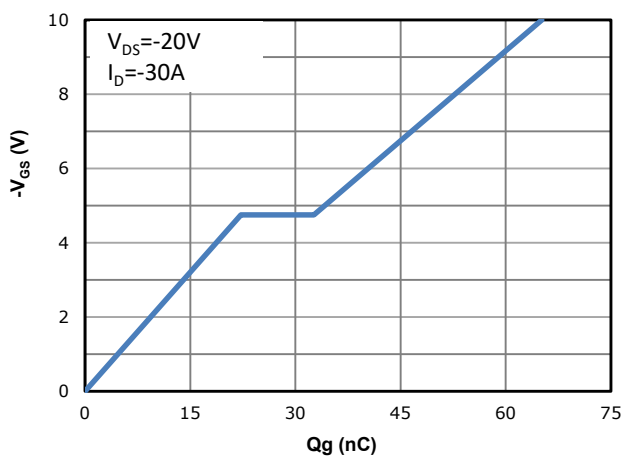

Fig 10: Body-diode Forward Characteristics

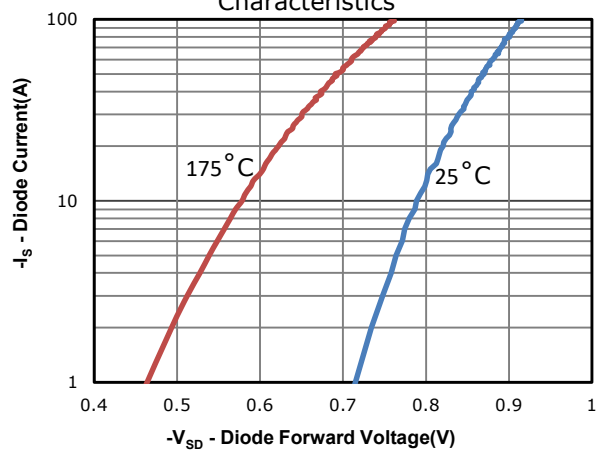

Fig 11: Power Dissipation

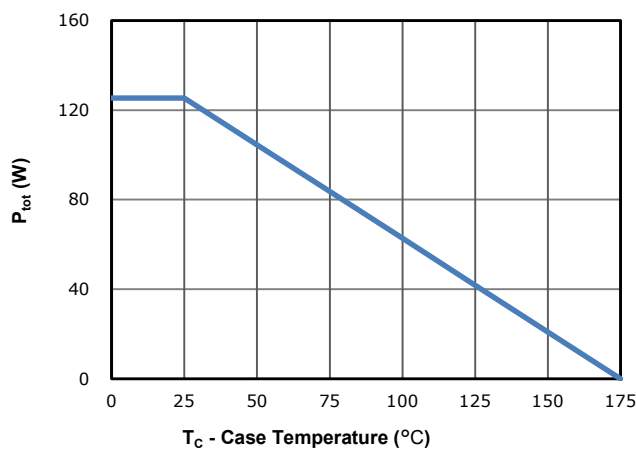

Fig 12: Drain Current Derating

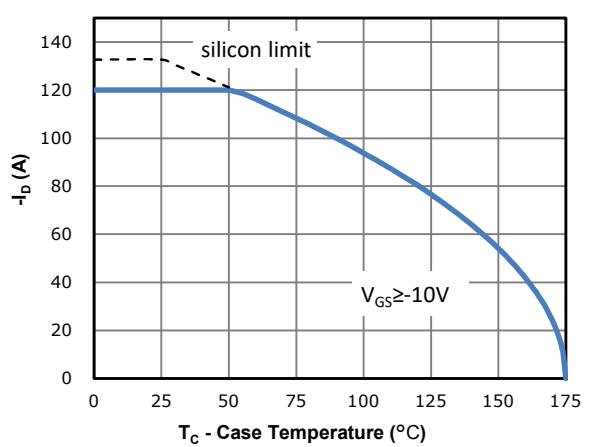

Fig 13: Safe Operating Area

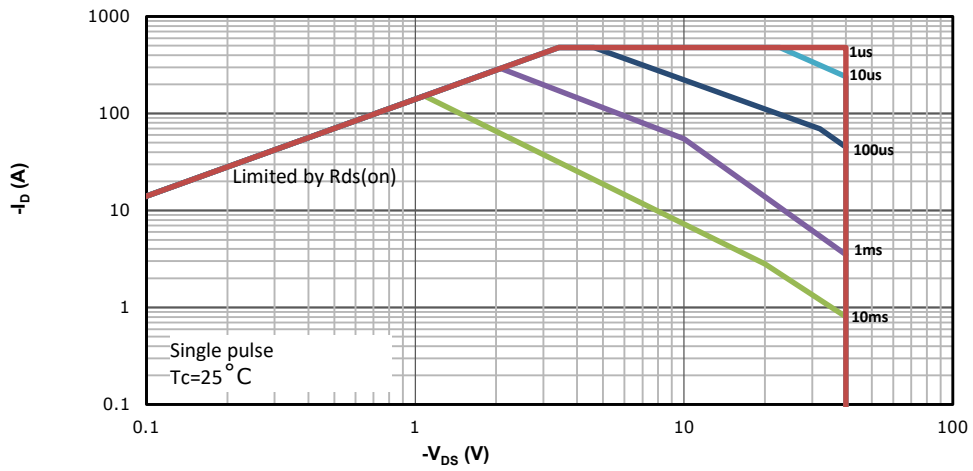
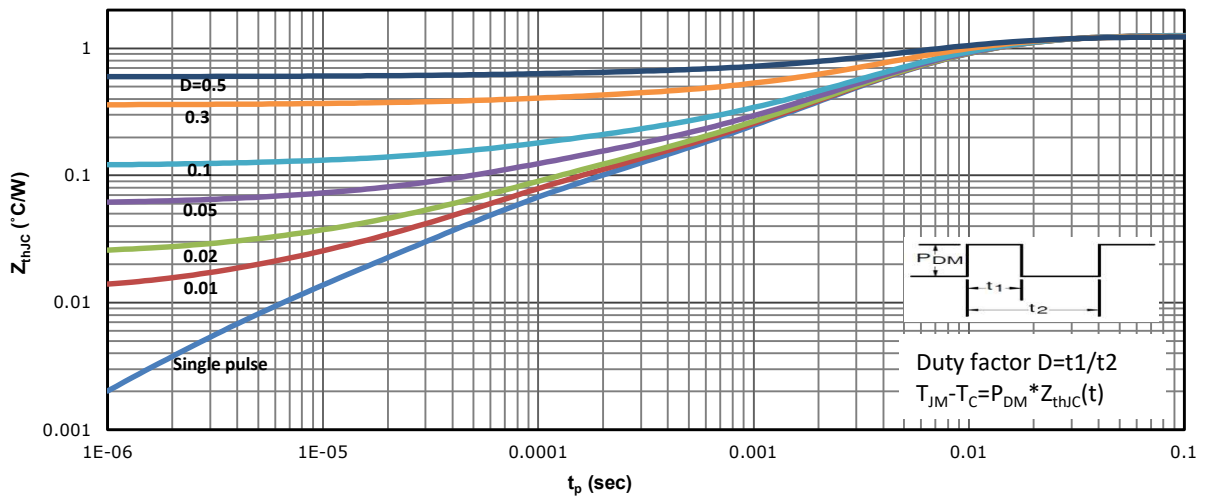
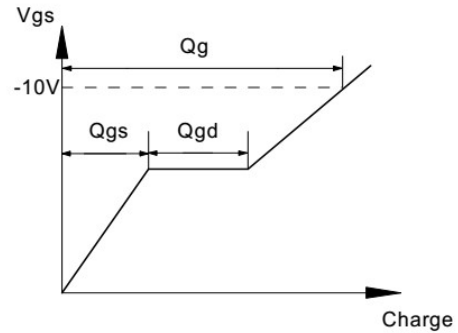
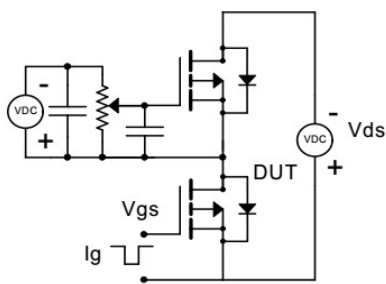

Fig 14: Max. Transient Thermal Impedance



## Test Circuit & Waveform

Gate Charge Test Circuit & Waveform



Resistive Switching Test Circuit & Waveforms

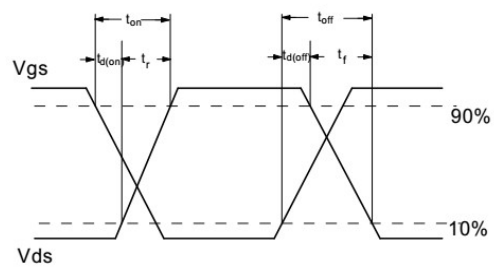
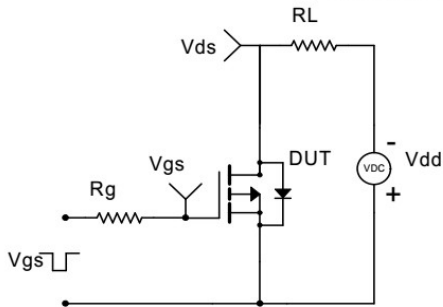

Unclamped Inductive Switching (UIS) Test Circuit & Waveforms

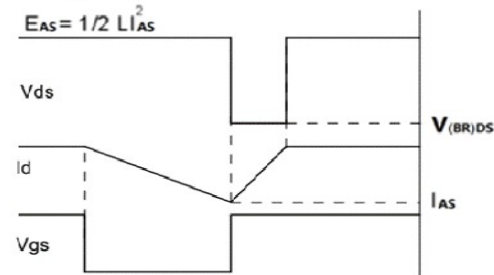
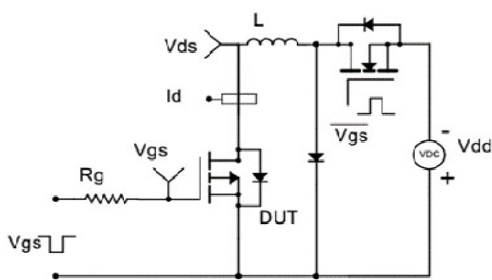

Diode Recovery Test Circuit & Waveforms

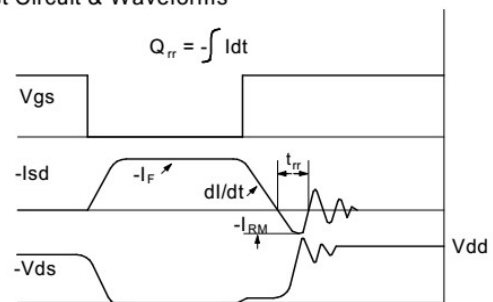
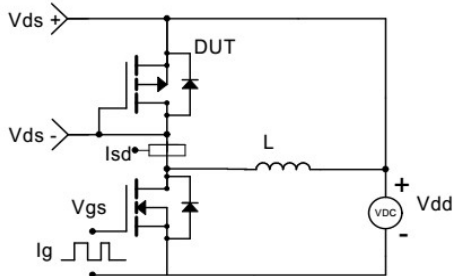

## Package Outline: DFN5X6

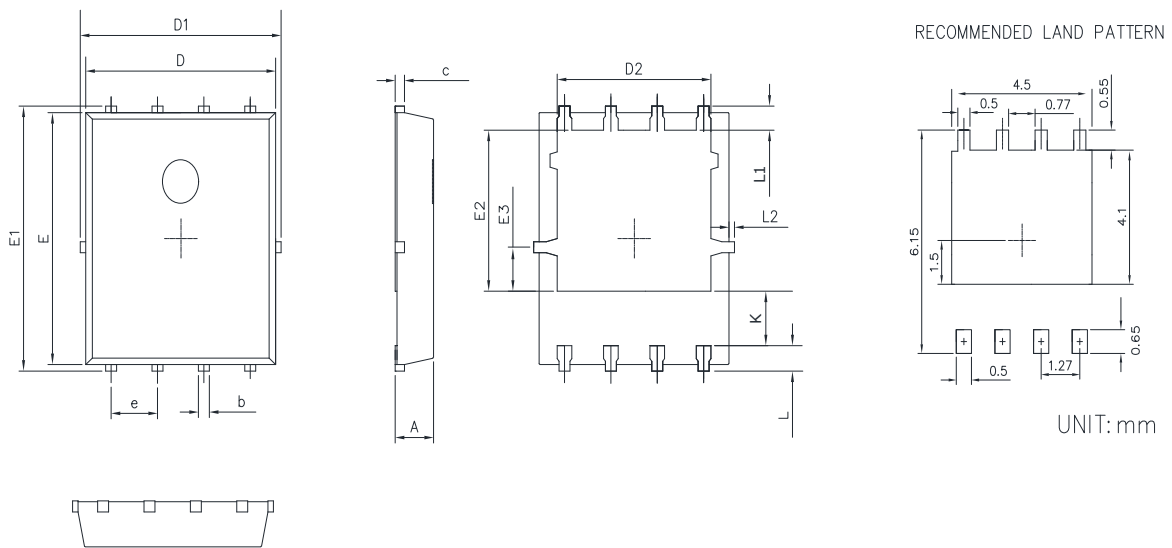

SYMBOL	MILLIMETERS		INCHES	
	MIN	MAX	MIN	MAX
A	0.90	1.10	0.035	0.043
b	0.25	0.50	0.010	0.020
c	0.10	0.30	0.004	0.012
D	4.80	5.30	0.189	0.209
D1	4.90	5.50	0.193	0.217
D2	3.92	4.20	0.154	0.165
E	5.65	5.85	0.222	0.230
E1	5.90	6.20	0.232	0.244
E2	3.33	3.78	0.131	0.149
E3	0.80	1.00	0.031	0.039
e	1.27		0.050	
L	0.40	0.70	0.016	0.028
L1	0.65		0.026	
L2	0.00	0.15	0.000	0.006
K	1.00	1.50	0.039	0.059



## Revision History

Revision	Date	Major changes
1.0	2025/4/29	First Release of Normal Version.
1.1	2025/6/6	Update Trr/Qrr/Gfs

## Disclaimer

Any and all semiconductor products have certain probability to fail or malfunction, which may result in personal injury, death or property damage. Customer are solely responsible for providing adequate safe measures when design their systems.

The product is not intended for use in applications that require extraordinary levels of quality and reliability, such as aviation/aerospace and life-support devices or systems.

Buyer is responsible for its products and applications using PingWei products, including compliance with all laws, regulations and safety requirements or standards, regardless of any support or applications information provided by PingWei.

“Typical” parameters which may be provided in PingWei data sheets and/or specifications can and do vary in different applications and actual performance may vary over time. All operating parameters, including “Typicals” must be validated for each customer application by customer’s technical experts

ALL PRODUCT, PRODUCT SPECIFICATIONS AND DATA ARE SUBJECT TO CHANGE WITHOUT NOTICE TO IMPROVE RELIABILITY. FUNCTION OR DESIGN OR OTHERWISE